

## 5 Phase Stepper Motor ( \*\* CE approved )

- Five leads for easy wiring configurations
- Wide selection range to suit various applications
- 0.3~63 Kgcm Max. Holding Torque
- Compact size for high Torque performance
- Highly cost effective
- conformed to CE standard ( for PCE range )



### 5 Phase Stepper Motor

Type	Motor Size (mm)	Motor Model	Max. Holding Torque (kgcm)	Rotor Inertia (gcm <sup>2</sup> )	Basic Step Angle***	Phase Current (Amps)	Motor Weight (kg)
HI-TORQUE	28	PEE 533 A (B) *	0.33	9	0.72°	0.75	0.1
		PEE 535 A (B) *	0.6	18	0.72°	0.75	0.17
	42	PF 543 AC (BC) *	1.3	35	0.72°	0.75	0.25
		PF 544 AC (BC) *	1.8	54	0.72°	0.75	0.3
		PF 545 AC (BC) *	2.4	68	0.72°	0.75	0.4
	60	PCE 5641 AC (BC)	4.2	175	0.72°	1.4	0.6
		PCE 5661 AC (BC)	8.3	280	0.72°	1.4	0.8
		PCE 5691 AC (BC)	16.6	560	0.72°	1.4	1.3
	85	PCE 5961 AC (BC)	20.9	1400	0.72°	1.4	1.7
		PCE 5991 AC (BC)	40.9	2700	0.72°	1.4	2.8
PCE 59131 AC (BC)		62.9	4000	0.72°	1.4	3.8	
HI-TORQUE HI-SPEED	60	PCE 5692 AC (BC)	16.6	560	0.72°	2.8	1.3
	85	PCE 5962 AC (BC)	20.9	1400	0.72°	2.8	1.7
		PCE 5992 AC (BC)	40.9	2700	0.72°	2.8	2.8
		PCE 59132 AC (BC)	62.9	4000	0.72°	2.8	3.8

### \*\* Brake Type Stepper Motor \*\*

HI-TORQUE *Brake Type	60	PCE 5641 ACM	4.2	320	0.72°	1.4	0.9
		PCE 5661 ACM	8.3	425	0.72°	1.4	1.1
		PCE 5691 ACM	16.6	705	0.72°	1.4	1.6
	85	PCE 5961 ACM	20.9	2200	0.72°	1.4	2.4
		PCE 5991 ACM	40.9	3500	0.72°	1.4	3.5
		PCE 59131 ACM	62.9	4800	0.72°	1.4	4.5
HI-TORQUE HI-SPEED *Brake Type	60	PCE 5692 ACM	16.6	705	0.72°	2.8	1.6
	85	PCE 5962 ACM	20.9	2200	0.72°	2.8	2.4
		PCE 5992 ACM	40.9	3500	0.72°	2.8	3.5
		PCE 59132 ACM	62.9	4800	0.72°	2.8	4.5

(AC) after the unit # denotes single shaft configuration. (BC) after the unit # denotes thru-shaft configuration.

\* CE approval not available for size 28 and 42mm motor range.

## Other Specifications

### Motor Electrical Specifications

Dielectric Strength	No abnormality detected after the application of 0.5KV at 50 Hz between motor windings and frame for duration of one minute		
Insulation Resistance	100 Mohms or better with 500V potential applied between motor windings and frame at normal ambient temperature and humidity		
Insulation Class	Class B	Operating Environment Temperature	0°C ~ + 50°C

### Motor Mechanical Specifications

Shaft Radial Play	0.025 mm (max) at load 0.5 Kg
Shaft Axial Play	0.075mm (max) at load 1 Kg
Step Angle Accuracy	± 3 min

## Applicable Driver Range

The above motors can be used on the following MYCOM stepping drivers. Selection is generally based on applicable speed range and supply input as indicated below :-

Low Speed Range ( 24Vdc supply input )

**UPS503 series**  
**IMS500 series**  
**INS500 series ( NanoDrive )**  
**INS501 series ( NanoDrive )**

Standard Speed Range ( 110Vac supply input )

**PSU50 series**  
**UPS52 series**  
**UPS53 series**  
**IMS50-x1x series**  
**INS50-x1x series ( NanoDrive )**

Standard Speed Range ( 220Vac supply input )

**IMS50-x2x series**  
**INS50-x2x series ( NanoDrive )**

\*\* kindly refer to our sales staff for other series of drivers

## 5 Phase Motor Connection Diagram

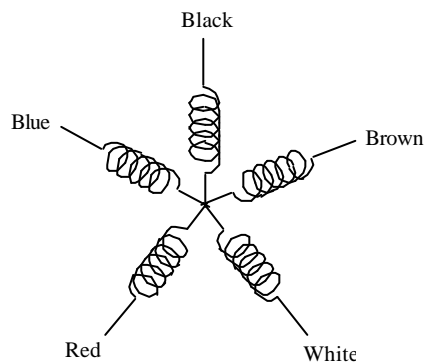

## 5 Phase Stepper Motor Dimensions – PEE 533 / PEE 535

PEE 53X-A(B)

Model No. A - Single Shaft B - Thru' Shaft	A (mm)	B (mm)
PEE 533-A(B)	31±1	42±2
PEE 535-A(B)	50.5±1	42±2

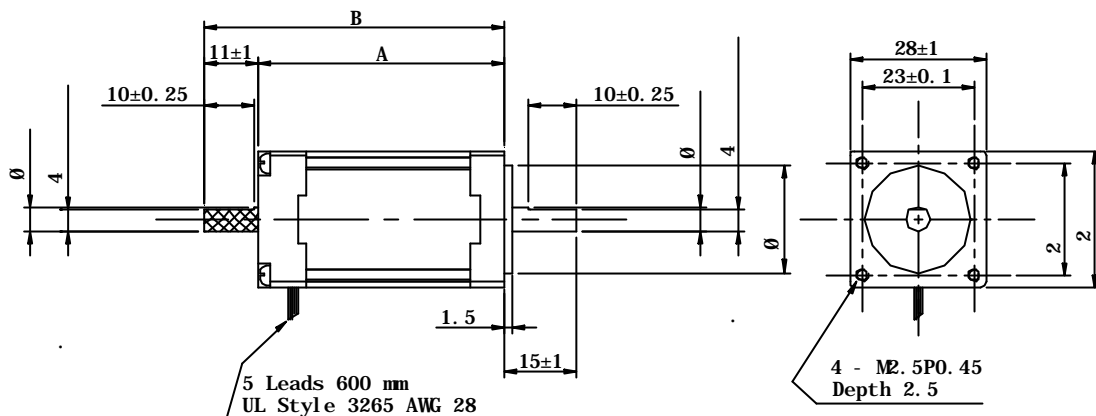

PEE 533-A(B) MG XX

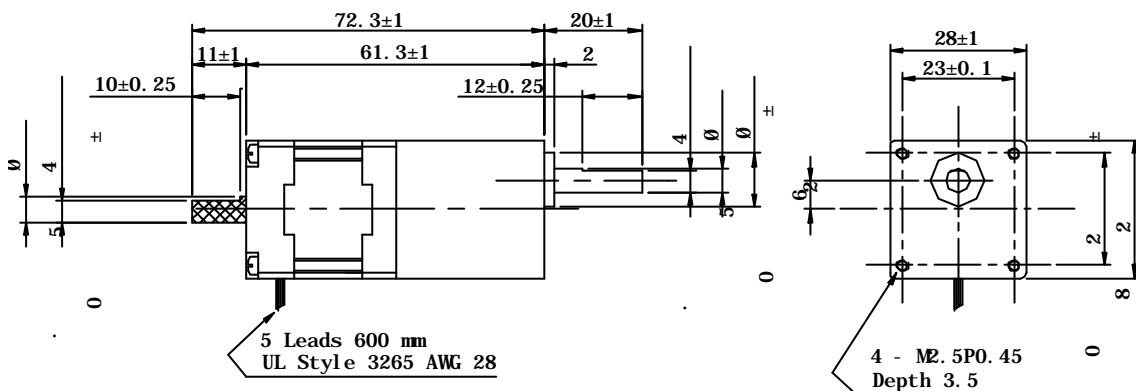

## 5 Phase Stepper Motor Dimensions – PF 543 / PF 544 / PF 545

Motor	L1	L2
PF543AC	33 ± 1	53 ± 1
PF543BC		68 ± 1
PF544AC	39 ± 1	59 ± 1
PF544BC		74 ± 1
PF545AC	47 ± 1	67 ± 1
PF545BC		82 ± 1

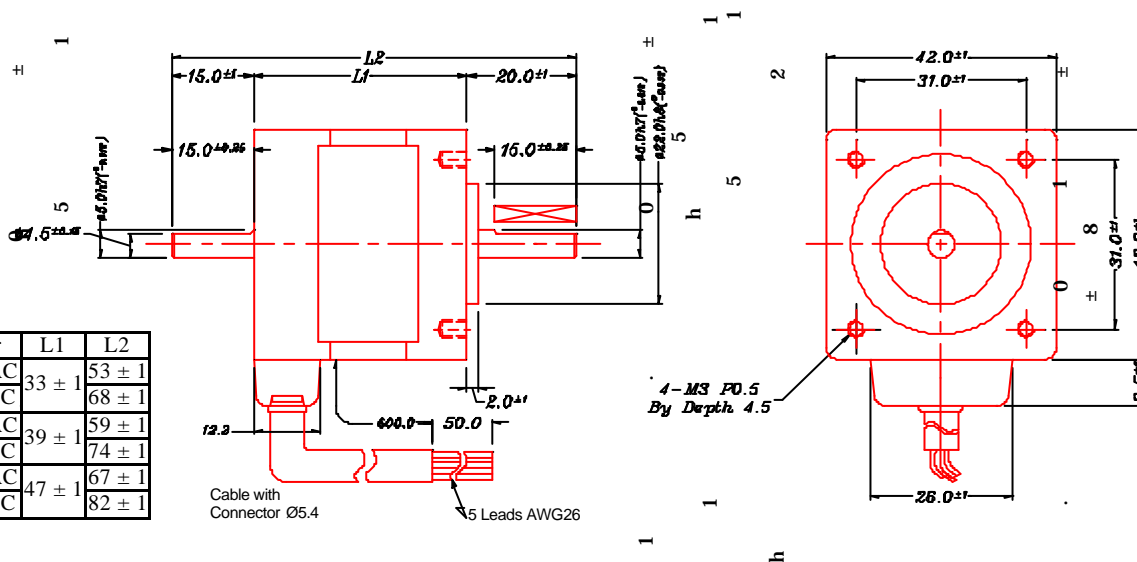

## 5 Phase Stepper Motor Dimensions – PCE 564x/PCE 566x/PCE 569x

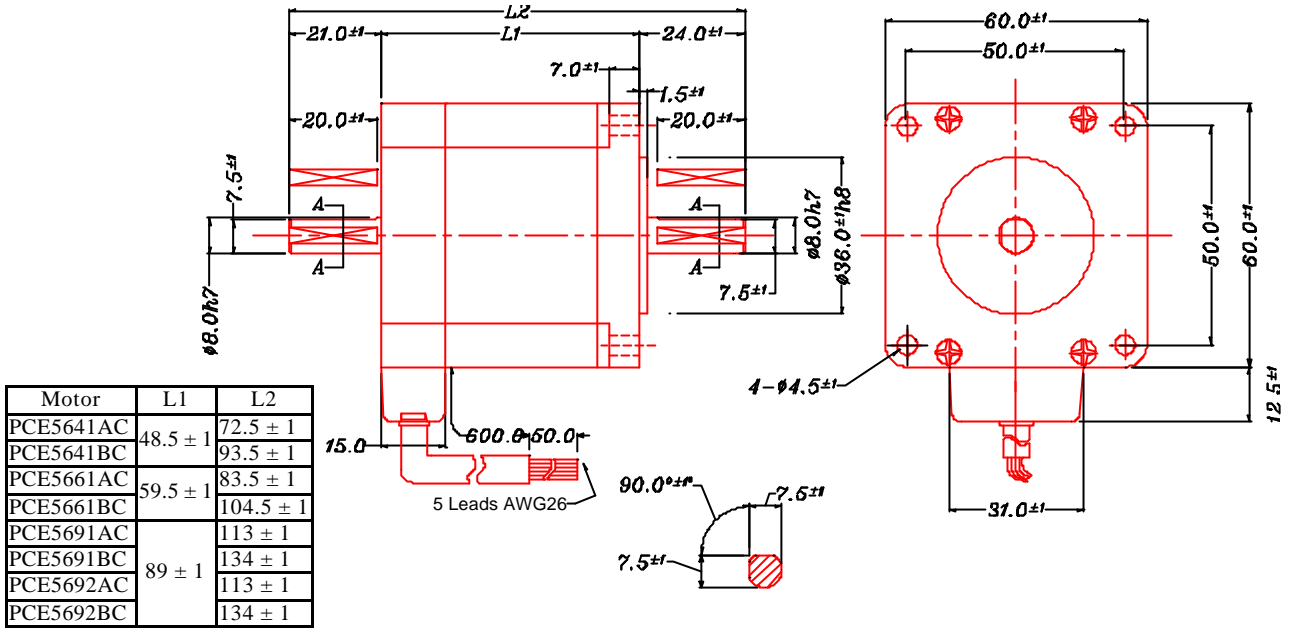

## 5 Phase Stepper Motor Dimensions – PCE 596x/PCE 599x/PCE 5913x

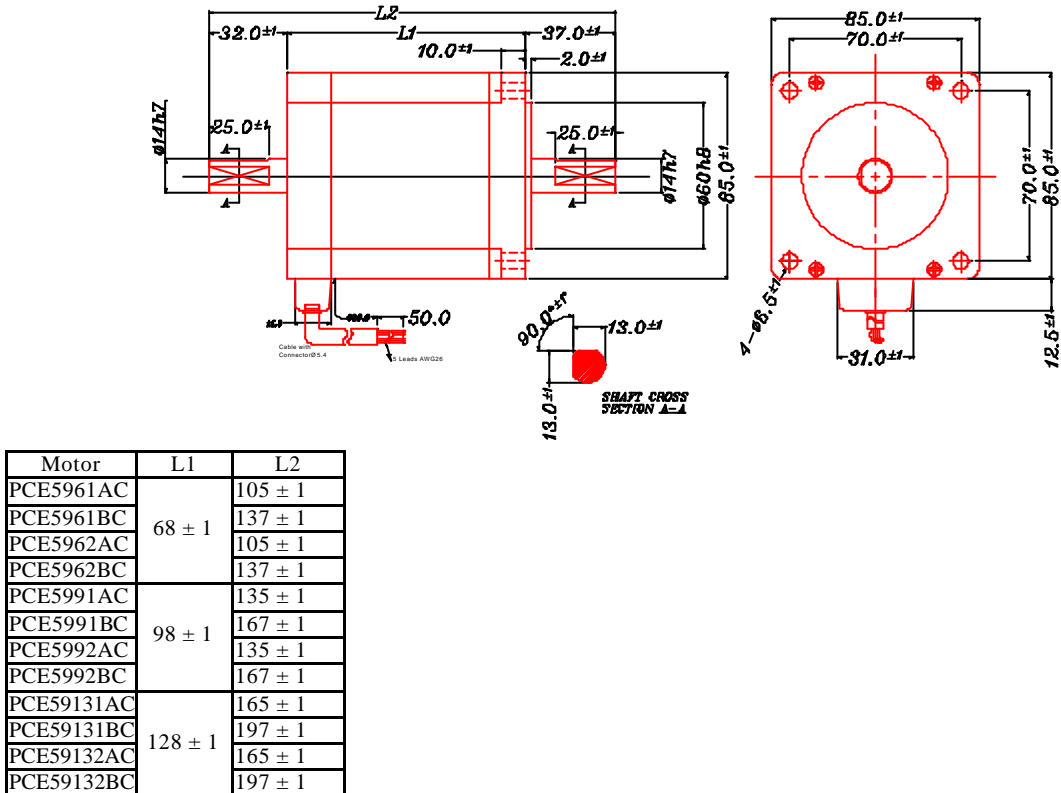

## Brake Type Stepper Motor Dimensions – PCE 56xx ACM

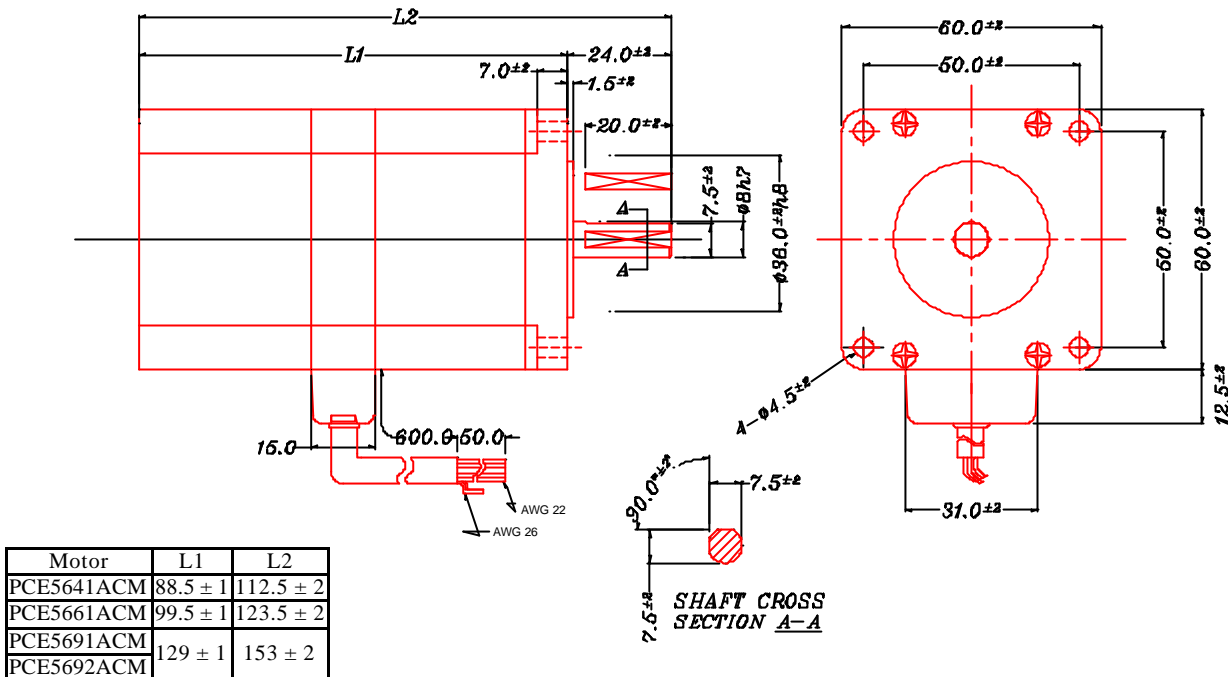

## Brake Type Stepper Motor Dimensions – PCE 59xxACM

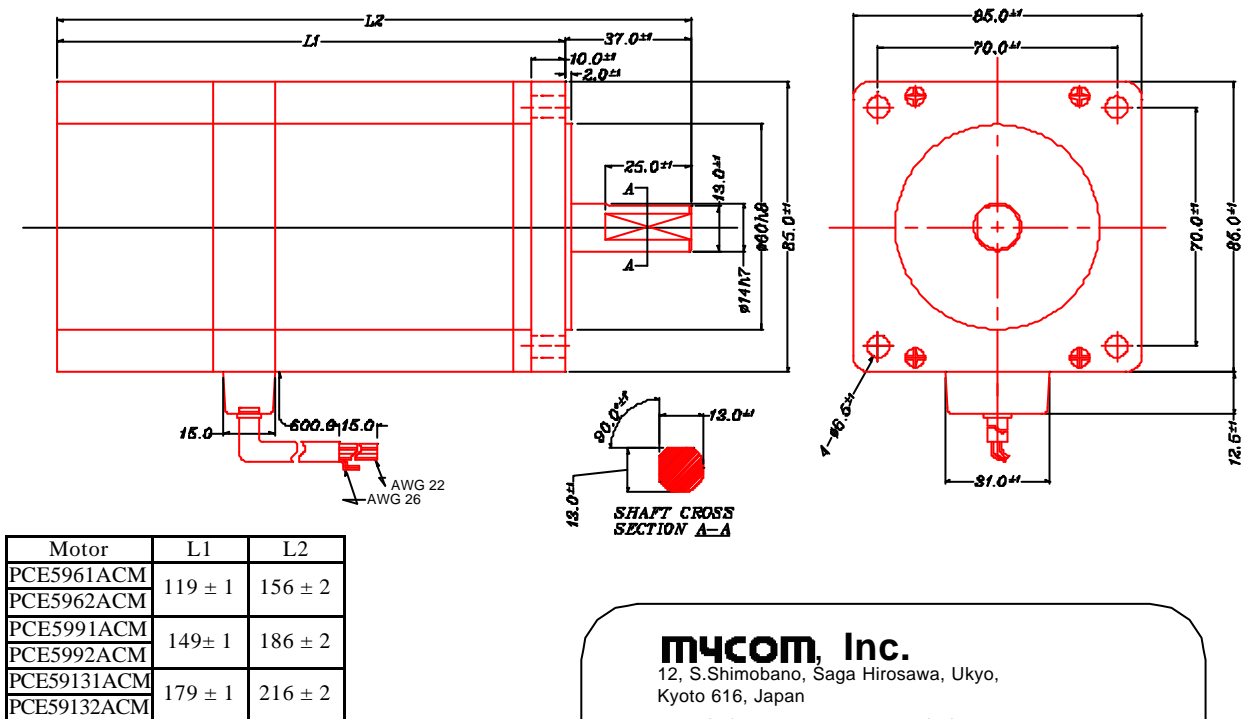

### MYCOM, Inc.

12, S. Shimobano, Saga Hirosawa, Ukyo,  
Kyoto 616, Japan

Tel : (81) 75-882-3601 Fax : (81) 75-880-6531

Email : support@mycom-japan.co.jp

### MYCOM Technology (S) Pte Ltd

No 1 Sims Lane, #05-05 One Sims Lane  
Singapore 387355

Tel : (065) 6743-4476 Fax : (065) 6743-4576

Email : sales@mycommts.com.sg